

Adjustable stroke 5.5mm

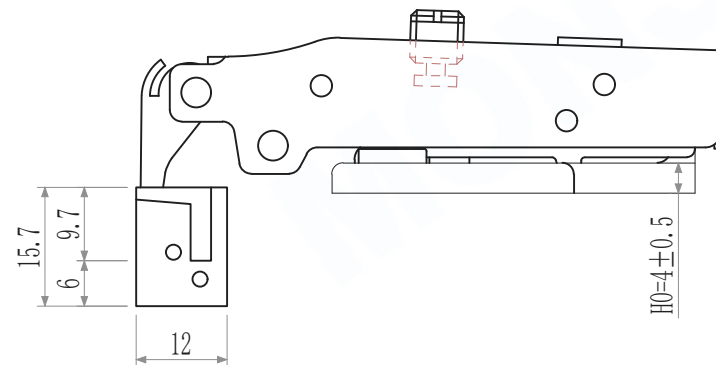
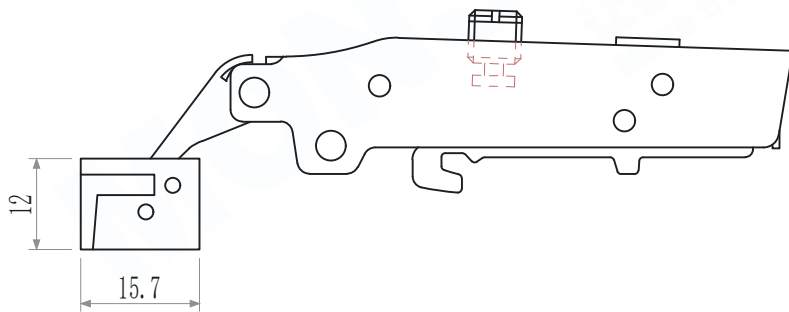

| range of sizes | tolerance |
|----------------|-----------|
| 0~3mm | ±0.05mm |
| 3~10mm | ±0.1mm |
| 10~30mm | ±0.25mm |
| 30~100mm | ±1mm |
| 100~300mm | ±3mm |
| Over 300mm | ±5mm |

Technical requirement
 1. Material: The main structure is zamactiron.
 2. Surface treatment: according to contract order requirements.

drawing no: M02681-01B

Item: One way clip on soft closing aluminum frame hinge

Page 1 of 1 Unit: mm

Main size: ▲ Proportion: 1:1

Date: 2022-9-23

Date: 2022-10-11

revise mark: ▲

reviser: Date:

describe: